

我愛你

STEFAN

Hate It Or Love It

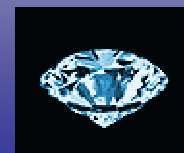

Man utd number  
9

Brazil  
9

Real Madrid  
Number 9

Gold and white  
vapours

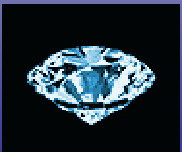

Name: Stefan Lee Age: 15

Challenge Group: Stefan

Challenge Group names:

**My School or youth Group:**  
Youth Group;  
Baggator,  
School;  
Brislington

**What I like doing most:**  
**Football!!**

**My fav colour:**  
Blue

**My Friends:**  
People

**My main interest are:**

**Football**

**My fav subject:**  
P.E

**My fav food:**  
Chicken  
rice &  
peas

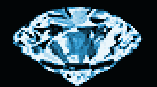
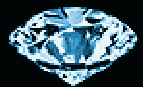

### **What I will do**

Help start an  
**'end to end'**  
Tournament and get  
a prize for the winner

### **What I am planning to do;**

I will get the names of the people who want to participate in the tournament.

Create a list that includes who will be playing and what person they will be playing with (according to their individual strategy and approach in relation to other players within the tournament).

Ensure that I am present at the match and cross-off people who are out of the tournament and go through the end of the match until there is an ultimate winner who will receive the prize.

# Activity sheet

### **Who will be involved**

Everyone who takes part in the competition

**Agreed by the challenge group**  
Signature and date.

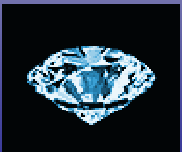

Discuss these questions with your friends in the challenge group and your youth worker or teacher. Tick the face which shows how you feel about the activity

High score	5	4	3	2	1	Low score
Very happy	y					Very unhappy
Gained confidence	y					Lost confidence
Learnt a lot	y					Learnt Little

The most fun part for me  
 See the games  
 Being played

Skills I have gained  
 Work with other people  
 With the games

Evidence in my portfolio of what I have done

The least fun part for me

Challenge group comments

---

Award worker comment  
 (by invitation)

Assessed by some of the challenge group  
 Shaista

Time spent (hours)

---

Date Assessed

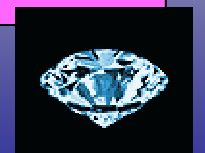

'This competition has given us the chance to express ourselves and explore and represent the interest towards everyone taking part in the setting'.

### What I will do

Make PowerPoint presentation on Badminton

Work as a group

Help with planning process and ideas

### What I am planning to do

We as a group will produce a power point presentation that demonstrates our passion for the sport; BADMINTON and the time scale that includes what different players will face one another. In addition, we will aim to use and share our skill within the group and with the help of Shaista who will support us throughout.

# Activity sheet

### Who will be involved

Stefan, Jake, Daniel, Jordan, Lizzie, Sana, Rinnele, Liam, Luke and Aishah

**Agreed by the challenge group**  
Signature and date.

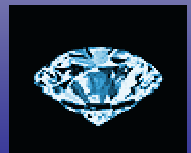
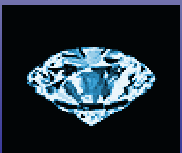

Stefan's, Jake's, Daniel's,  
Jordan's, Lizzie's, Sana's,  
Rinnele's, Liam's Luke's and  
Aishah's

Badminton tournament

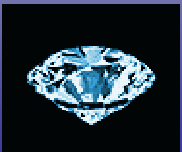

# Why Badminton???

- Badminton is a sport we all have a keen interest in displaying and demonstrating toward our peers!
- This competition has given us the chance to express ourselves and explore and represent the interest towards everyone taking part in the setting.

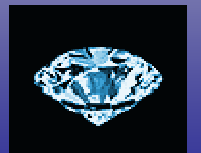
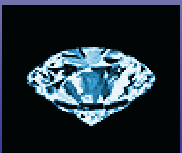

# What we will do...

- We are addressing the possible ways in which we can display the people taking part in the badminton tournament in order to create a schedule whereby everyone who wants to take part can take part.
- In addition, we will ask around for all people who want to take part and make a decision on their capability in order that they are given a fair deal throughout the competition.

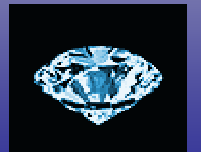
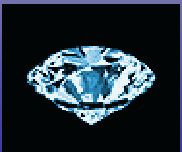

# Badminton Schedule

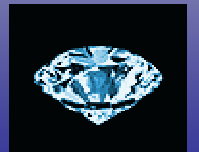
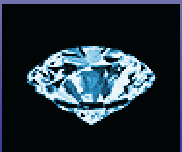
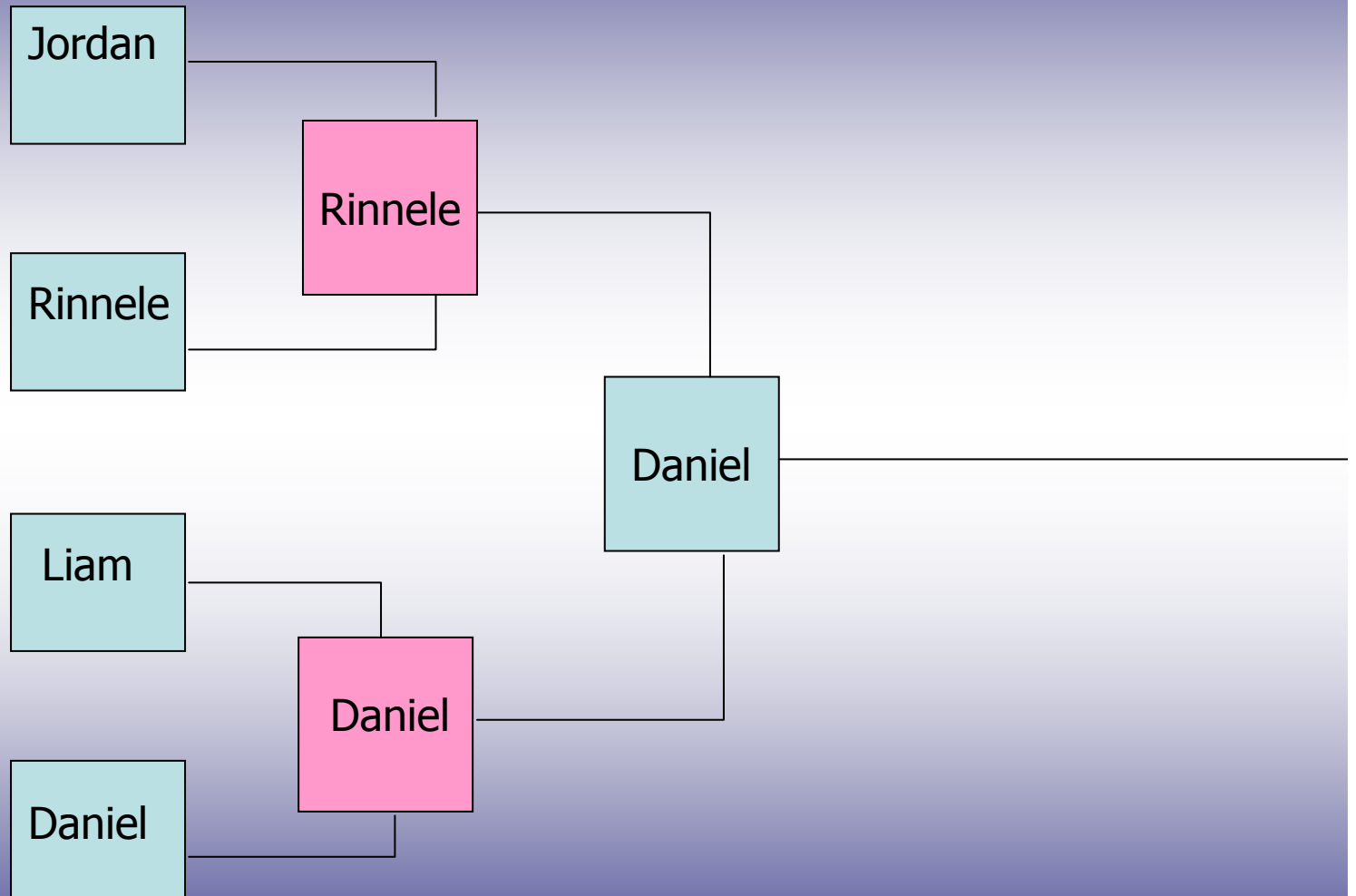

# Badminton Schedule cont...

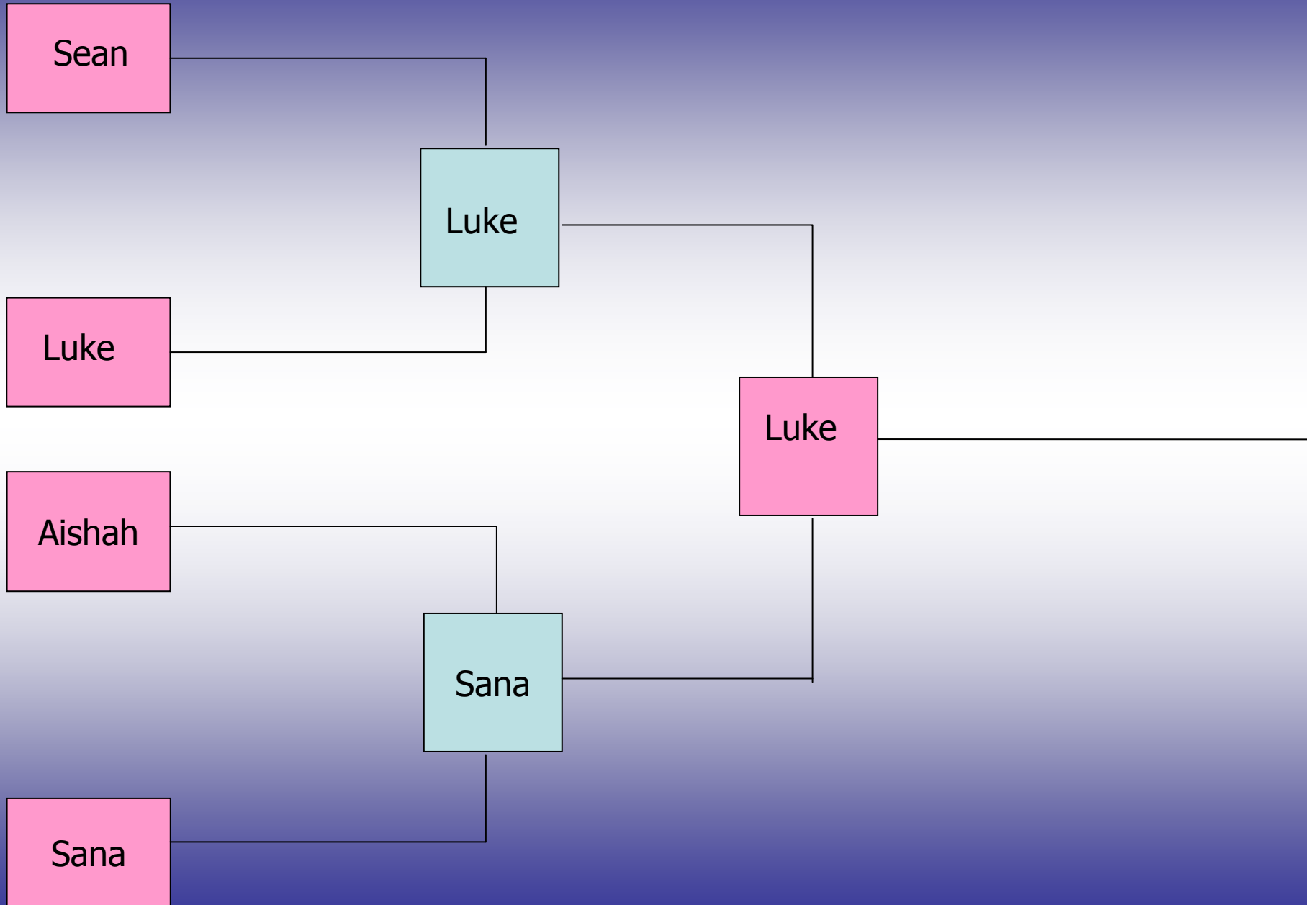

# Winner

**DANIEL**

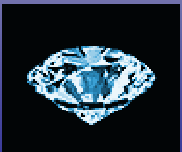

Discuss these questions with your friends in the challenge group and your youth worker or teacher. Tick the face which shows how you feel about the activity

High score	5	4	3	2	1	Low score
Very happy	y					Very unhappy
Gained confidence	y					Lost confidence
Learnt a lot	y					Learnt Little

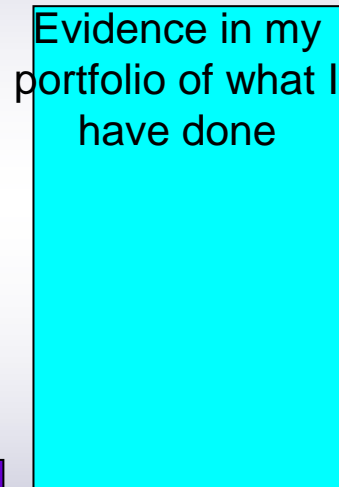
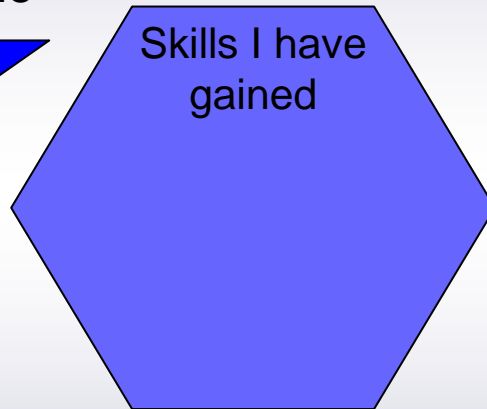

Challenge group comments
Award worker comment (by invitation)

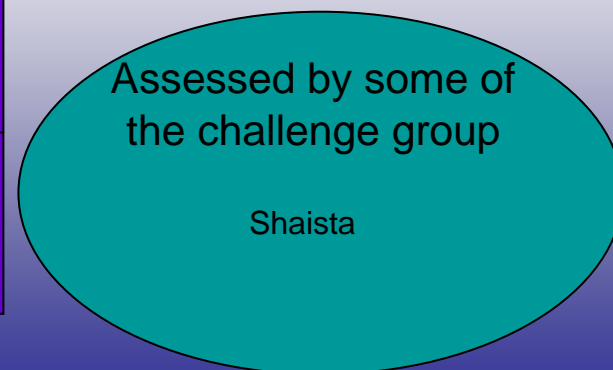

Time spent (hours)
Date Assessed

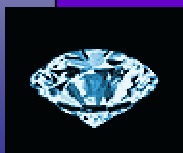

## What I will do

To create an email address through hotmail as this is the first time I will be using the internet in this way, I will ensure that all information I put online will be stored so if I forget my password, I am able to use my secret word to regain access to my e-mail

## What I am planning to do

I will require assistance on gaining access to the internet I will type in a suitable email address that I will be able to use in the future. Type in the http address as <http://www.hotmail.com> ----- for a new e-mail sign up. Fill in personal details. In addition, use this to pass information and sent pictures to Shaista as part of the project for the youth achievement awards.

# Activity sheet

## Who will be involved

Everyone taking part in the Youth Achievement Awards

**Agreed by the challenge group**  
Signature and date.

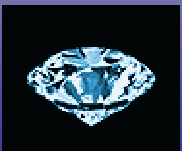

Discuss these questions with your friends in the challenge group and your youth worker or teacher. Tick the face which shows how you feel about the activity

High score	5	4	3	2	1	Low score
Very happy	y					Very unhappy
Gained confidence	y					Lost confidence
Learnt a lot	y					Learnt Little

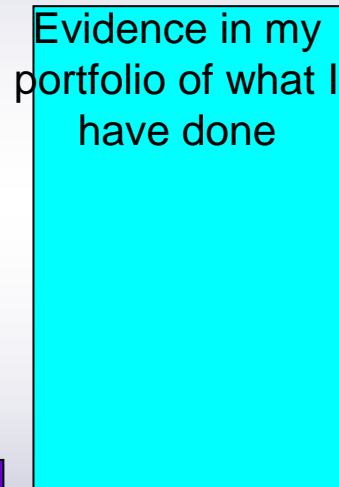
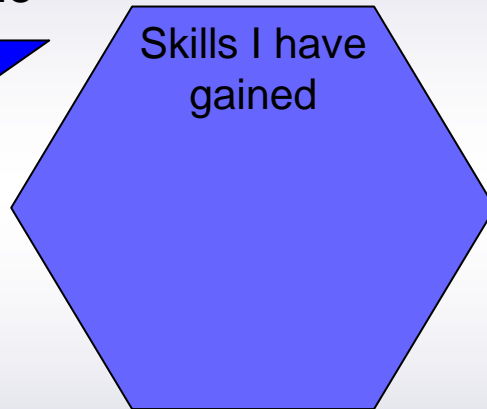

Challenge group comments

---

Award worker comment  
(by invitation)

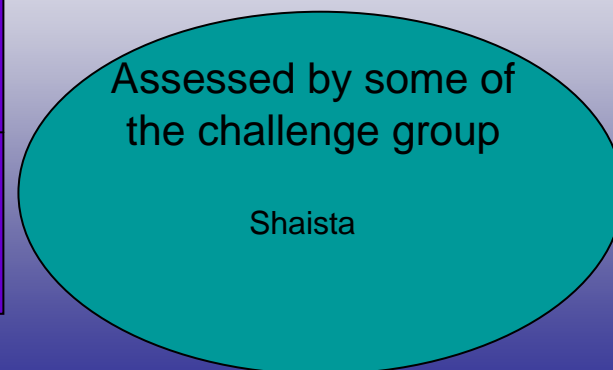

Time spent (hours)

---

Date Assessed

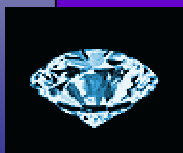

'We will ask around for all people who want to take part and make a decision on their capability in order that they are given a fair deal throughout the competition'.

### What I will do

To take part in the badminton tournament that I have prepared with theory for and also practised

### What I am planning to do

To help prepare with the set-up of the court amongst the other participants taking part in the competition. I will aim to achieve my potential and express myself in a respectful manner when discussing whether the points are in within the competition. So therefore, I will not argue with the refs decision. (The final decision by the ref will stand). If for any reason I do not take part, I will be either joint ref or ensuring order in the game.

# Activity sheet

### Who will be involved

Stefan, Jake, Daniel, Jordan, Lizzie, Sana, Rinnele, Liam, Sean, Luke and Aishah

**Agreed by the challenge group**  
Signature and date.

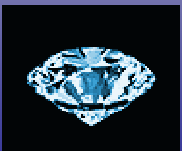

Discuss these questions with your friends in the challenge group and your youth worker or teacher. Tick the face which shows how you feel about the activity

High score	5	4	3	2	1	Low score
Very happy	y					Very unhappy
Gained confidence	y					Lost confidence
Learnt a lot	y					Learnt Little

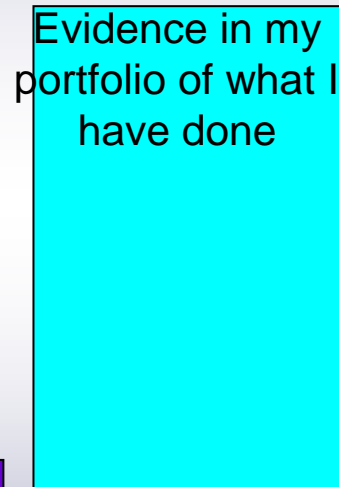
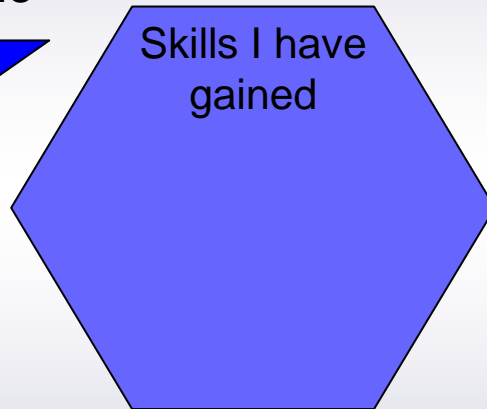

Challenge group comments

---

Award worker comment  
(by invitation)

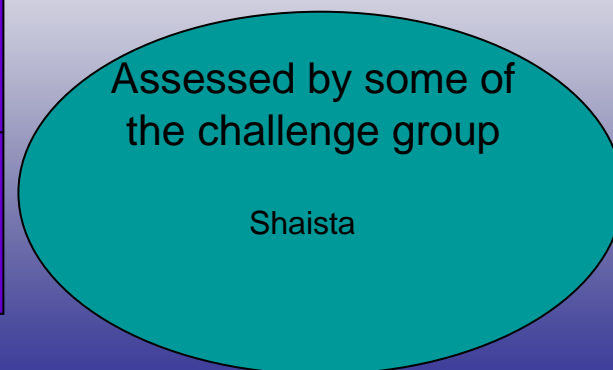

Time spent  
(hours)

---

Date  
Assessed

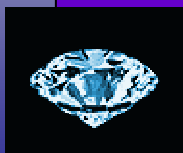

**What I am planning to do**

**What I will do**

# Activity sheet

**Who will be involved**

**Agreed by the challenge group**  
Signature and date.

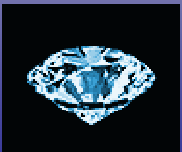

Discuss these questions with your friends in the challenge group and your youth worker or teacher. Tick the face which shows how you feel about the activity

High score	5	4	3	2	1	Low score
Very happy	y					Very unhappy
Gained confidence	y					Lost confidence
Learnt a lot	y					Learnt Little

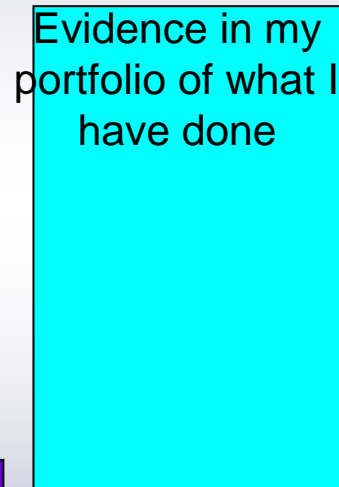
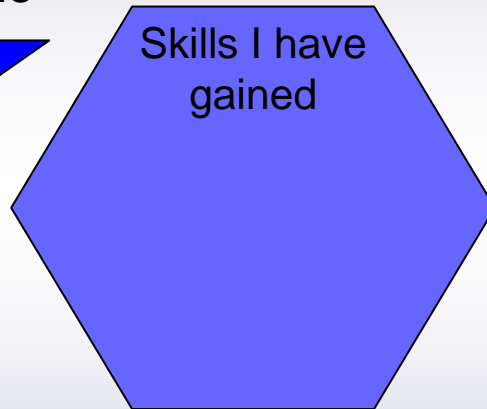

Challenge group comments
Award worker comment (by invitation)

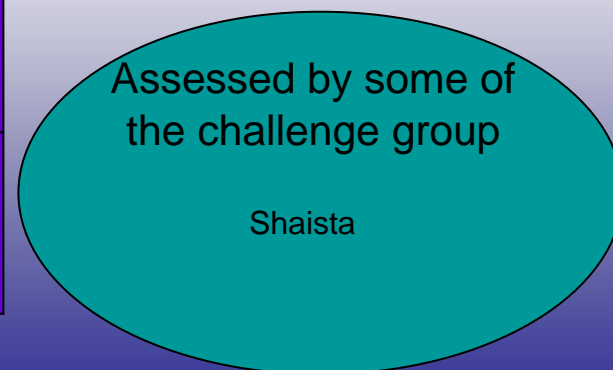

Time spent (hours)
Date Assessed

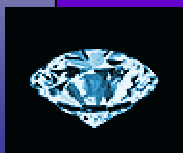

**What I am planning to do**

**What I will do**

# Activity sheet

**Who will be involved**

**Agreed by the challenge group**  
Signature and date.

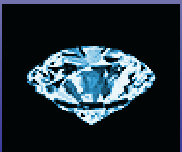

Discuss these questions with your friends in the challenge group and your youth worker or teacher. Tick the face which shows how you feel about the activity

High score	5	4	3	2	1	Low score
Very happy	y					Very unhappy
Gained confidence	y					Lost confidence
Learnt a lot	y					Learnt Little

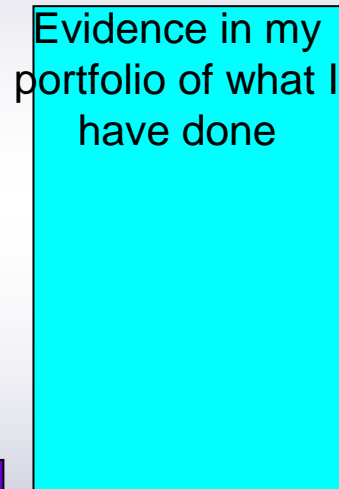
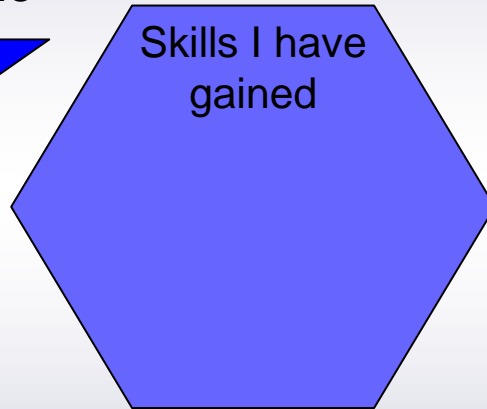

Challenge group comments

---

Award worker comment  
(by invitation)

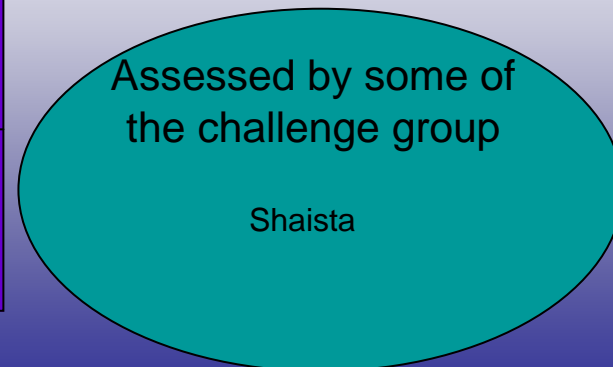

Time spent (hours)

---

Date Assessed

