

JAKE



**Name:** Jake Shaw      **Age:** 14  
**Challenge Group:** Ching Chong China

**Challenge Group names:** Luke L, Sean, Luke E, Liam W, Rachid

**My School or youth Group:**  
Youth Group;  
Baggator,  
School; City  
Academy

**What I like doing most:**  
**Sleeping**

**My fav colour:**  
Red

**My Friends:**  
Me, Luke L, Luke  
E, Sean, Rachid

**My main interest are:**  
**Sleeping**

**My fav subject:**  
Me

**My fav food:**  
Pizza



'This competition has given us the chance to express ourselves and explore and represent the interest towards everyone taking part in the setting'.

### What I will do

- Make PowerPoint presentation on Badminton
- Work as a group
- Help with planning process and ideas

### What I am planning to do

We as a group will produce a power point presentation that demonstrates our passion for the sport; BADMINTON and the time scale that includes what different players will face one another. In addition, we will aim to use and share our skill within the group and with the help of Shaista who will support us throughout.

# Activity sheet

### Who will be involved

Stefan, Jake, Daniel, Jordan, Lizzie, Sana, Rinnele, Liam, Luke and Aishah

**Agreed by the challenge group**  
Signature and date.



Stefan's, Jake's, Daniel's,  
Jordan's, Lizzie's, Sana's,  
Rinnele's, Liam's Luke's and  
Aishah's

Badminton tournament



# Why Badminton???

- Badminton is a sport we all have a keen interest in displaying and demonstrating toward our peers!
- This competition has given us the chance to express ourselves and explore and represent the interest towards everyone taking part in the setting.



# What we will do...

- We are addressing the possible ways in which we can display the people taking part in the badminton tournament in order to create a schedule whereby everyone who wants to take part can take part.
- In addition, we will ask around for all people who want to take part and make a decision on their capability in order that they are given a fair deal throughout the competition.



# Badminton Schedule

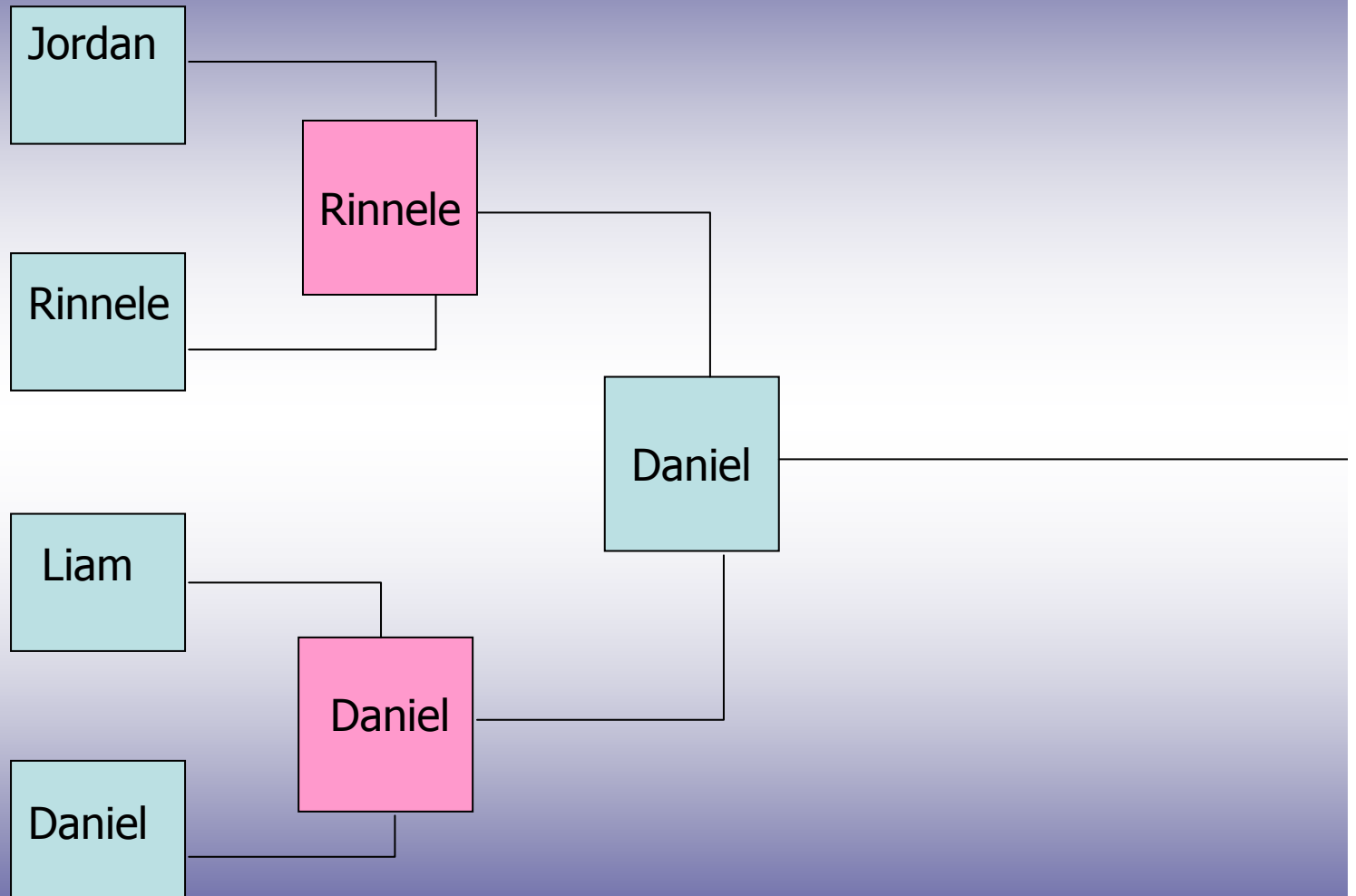

# Badminton Schedule cont...

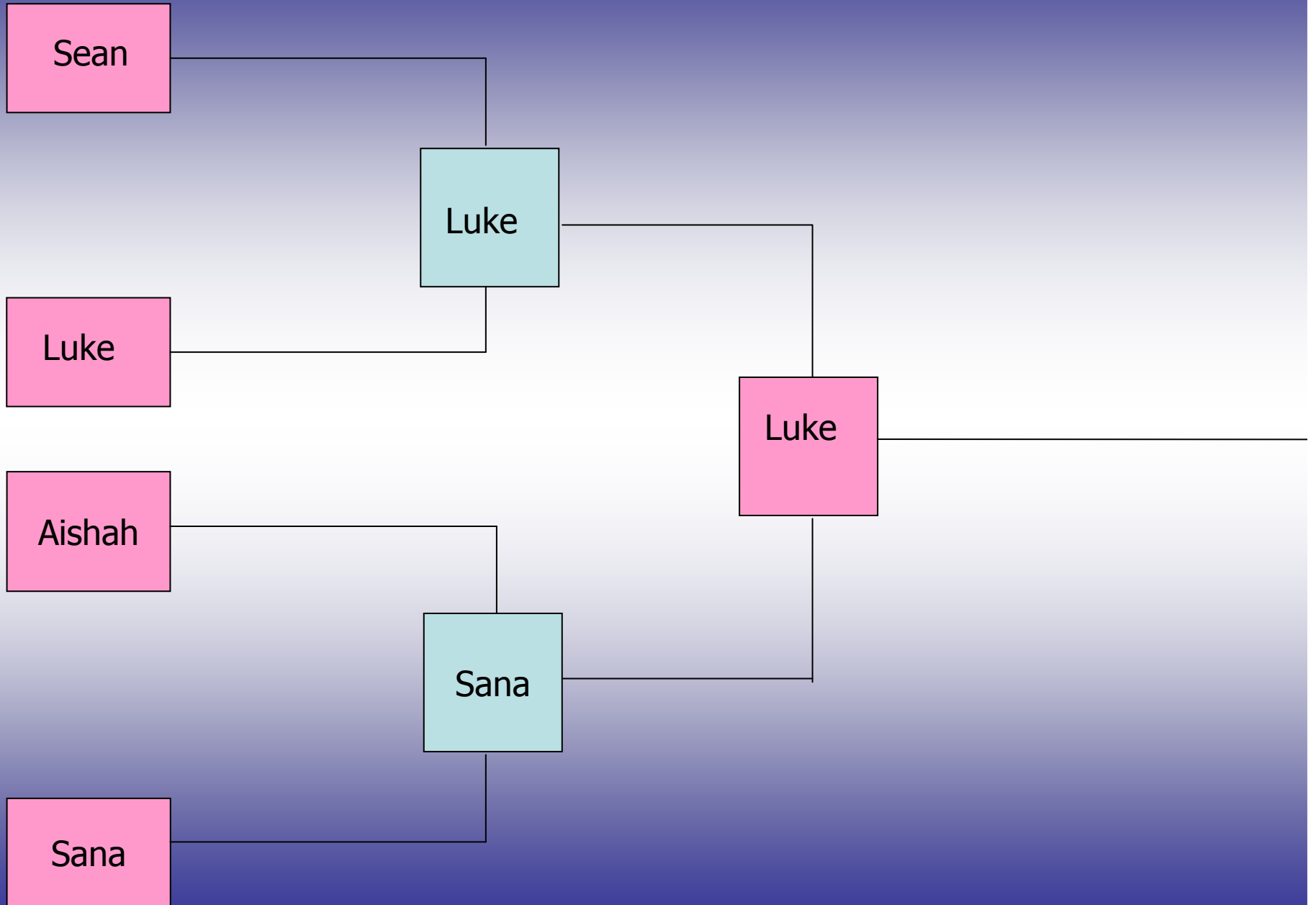

# Winner

# DANIEL



Discuss these questions with your friends in the challenge group and your youth worker or teacher. Tick the face which shows how you feel about the activity

High score	5	4	3	2	1	Low score
Very happy		y				Very unhappy
Gained confidence	y					Lost confidence
Learnt a lot	y					Learnt Little

The most fun part for me

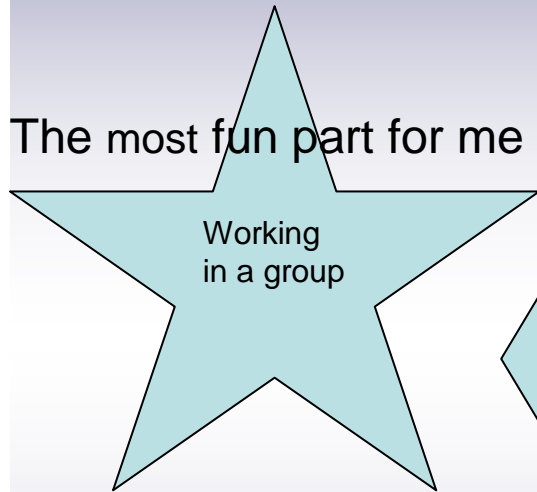

Working  
in a group

Skills I have  
gained



How to put together  
a presentation, and  
learning new skills  
about badminton!

Evidence in my  
portfolio of what I  
have done

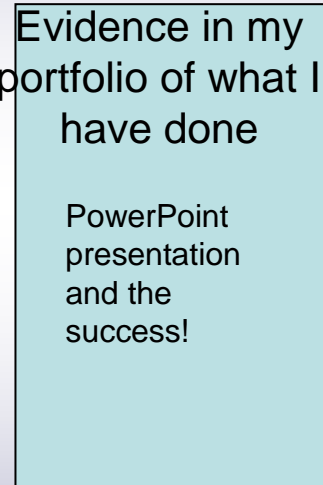

PowerPoint  
presentation  
and the  
success!

The least fun  
part for me



All the effort  
that had to  
be put in!

Challenge group comments

Award worker comment  
(by invitation)



Assessed by some of  
the challenge group

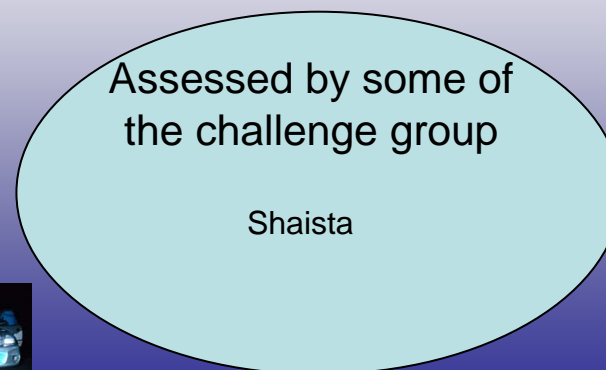

Shaista

Time spent  
(hours)

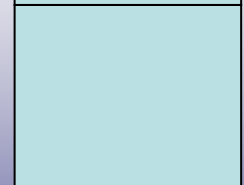

Date Assessed



## What I will do

To create an email address through hotmail as this is the first time I will be using the internet in this way, I will ensure that all information I put online will be stored so if I forget my password, I am able to use my secret word to regain access to my e-mail

## What I am planning to do

I will require assistance on gaining access to the internet I will type in a suitable email address that I will be able to use in the future. Type in the http address as <http://www.hotmail.com> ----- for a new e-mail sign up. Fill in personal details. In addition, use this to pass information and sent pictures to Shaista as part of the project for the youth achievement awards.

# Activity sheet

## Who will be involved

Everyone taking part in the Youth Achievement Awards

**Agreed by the challenge group**  
Signature and date.



**Discuss these questions with your friends in the challenge group and your youth worker or teacher. Tick the face which shows how you feel about the activity**

High score	5	4	3	2	1	Low score
Very happy		y				Very unhappy
Gained confidence	y					Lost confidence
Learnt a lot		y				Learnt Little

**The most fun part for me**  
 Giving my address to people and talking to them!

**Skills I have gained**  
 Online skills, and able to talk to people from all over the world!

**Evidence in my portfolio of what I have done**  
 My email address and I use msn messenger!

**The least fun part for me**  
 Filling in personal details!

Challenge group comments

---

Award worker comment  
 (by invitation)

**Assessed by some of the challenge group**  
 Shaista

Time spent (hours)

---

Date Assessed



'We will ask around for all people who want to take part and make a decision on their capability in order that they are given a fair deal throughout the competition'.

### What I will do

To take part in the badminton tournament that I have prepared with theory for and also practised

### What I am planning to do

To help prepare with the set-up of the court amongst the other participants taking part in the competition. I will aim to achieve my potential and express myself in a respectful manner when discussing whether the points are in within the competition. So therefore, I will not argue with the refs decision. (The final decision by the ref will stand). If for any reason I do not take part, I will be either joint ref or ensuring order in the game.

# Activity sheet

### Who will be involved

Stefan, Jake, Daniel, Jordan, Lizzie, Sana, Rinnele, Liam, Sean, Luke and Aishah

**Agreed by the challenge group**  
Signature and date.



Discuss these questions with your friends in the challenge group and your youth worker or teacher. Tick the face which shows how you feel about the activity

High score	5	4	3	2	1	Low score
Very happy			y			Very unhappy
Gained confidence	y					Lost confidence
Learnt a lot	y					Learnt Little

The most fun part for me



Skills I have gained



Evidence in my portfolio of what I have done

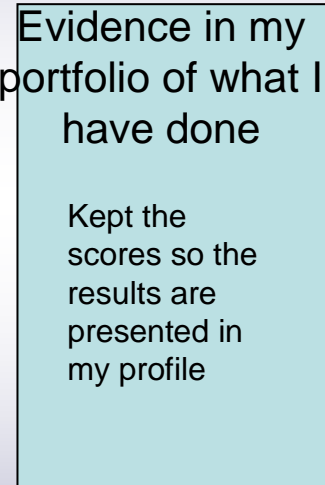

The least fun part for me



Challenge group comments

Award worker comment  
(by invitation)



Assessed by some of the challenge group

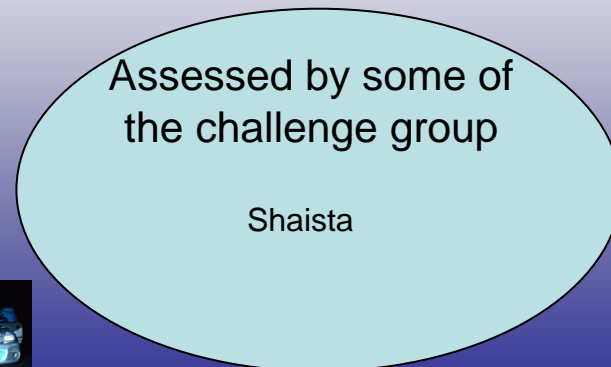

Time spent (hours)

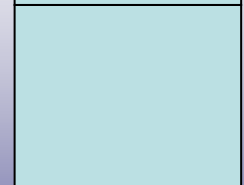

Date Assessed



## What I will do

In order to take part in the camp, I must ensure that I can be responsible and follow instructions at Baggator club and take an active role in information in relation to the camp, in that I must ensure that I hand in my consent form and my money on time. Ensure I follow instructions given by all members of staff on camp; Pete, Sally, Farooq and Shaista.

## What I am planning to do

CAMP; being good to ensure we are safe and that it can provide a fun and safe environment for all through our participation, carrying out instructions efficiently and constructively, have 'FUN' and be on the ball when need be and considerate to others feelings. Take an active role in the activities that have been provided, i.e. surfing, boat fishing trip (could be a chance to overcome fears). As the site we will be staying on is carrying a lot of other holiday makers and bearing in mind that we will sometimes be back late at night for the reason of night walks etc, we must ensure that we do not make too much noise on the campsite area so that the other campers are not disturbed. At the end of camp, we must all ensure that we clean up all of our mess and ensure during the week that all mess is put in the bins provided.

# Activity sheet

**Agreed by the challenge group**  
**Signature and date.**

## Who will be involved

Melissa, Jordan, Liam,  
Daniel, Luke. L, Luke. E,  
Lizzie, Jake, Sean, Tawana,  
Lewis, Aishah.



Discuss these questions with your friends in the challenge group and your youth worker or teacher. Tick the face which shows how you feel about the activity

High score	5	4	3	2	1	Low score
Very happy			y			Very unhappy
Gained confidence		y				Lost confidence
Learnt a lot		y				Learnt Little

The most fun part for me

Was being involved in all activities!

Skills I have gained

Independence, working in a team! And gaining more confidence!

Evidence in my portfolio of what I have done

Photographic evidence

The least fun part for me

Having to go to sleep!!!!!!!!!!!!!!!!!!!!

Challenge group comments

Award worker comment (by invitation)

Assessed by some of the challenge group

Shaista

Time spent (hours)

Date Assessed



## What I will do

To organise a Bases competition that I will take in a Wednesday night session of Baggator. The people taking part in the competition will be randomly selected from names put into a hat. The competition will include people from different set abilities in their skills of basketball shooting.

## What I am planning to do

I will work alongside Shaista because even though I am quite a new member at the setting, I find that I have fitted in quite well. However, I have not yet familiarised myself with the names of the many people who are regular at the session so working with the help of Shaista will help me develop in my communication skills that in accordance will have a positive affect on my self-esteem. The competition will be set-up on a winner stays on basis. The winning total for the number of shots will be '15' for the first round and '21' for the second and the results will be recorded by the ref who will be appointed at the time of the match.

# Activity sheet

## Who will be involved

Hannaa, Adeola, Sadia, Shaista, Jake, Aishah, and Sana.

**Agreed by the challenge group**  
Signature and date.



ROUND 1

ROUND 2

HANNAA

12

3rd

15

4th

SADIA

14

2nd

19

2nd

SHAISTA

15

1st

21

1st

ADEOLA

6

5th

11

5th

JAKE

0

6th

17

3rd

AISHAH

10

4th

0

6th

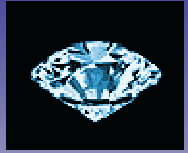

Winner...

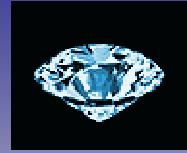

Shaista

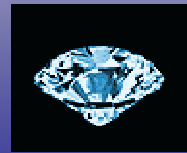
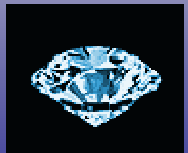

**Discuss these questions with your friends in the challenge group and your youth worker or teacher. Tick the face which shows how you feel about the activity**

High score	5	4	3	2	1	Low score
Very happy	y					Very unhappy
Gained confidence	y					Lost confidence
Learnt a lot	y					Learnt Little

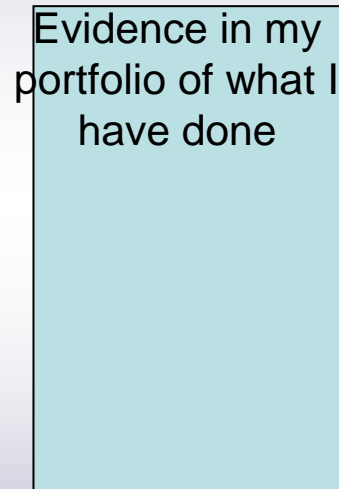
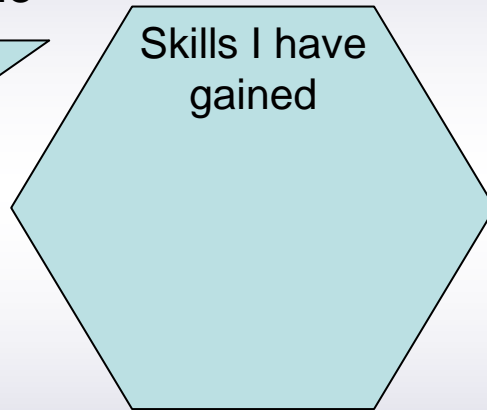

Challenge group comments
Award worker comment (by invitation)

Assessed by some of the challenge group

Shaista

Time spent (hours)
Date Assessed



**What I am planning to do**

**What I will do**

# Activity sheet

**Who will be involved**

**Agreed by the challenge group**  
Signature and date.



Discuss these questions with your friends in the challenge group and your youth worker or teacher. Tick the face which shows how you feel about the activity

High score	5	4	3	2	1	Low score
Very happy	y					Very unhappy
Gained confidence	y					Lost confidence
Learnt a lot	y					Learnt Little

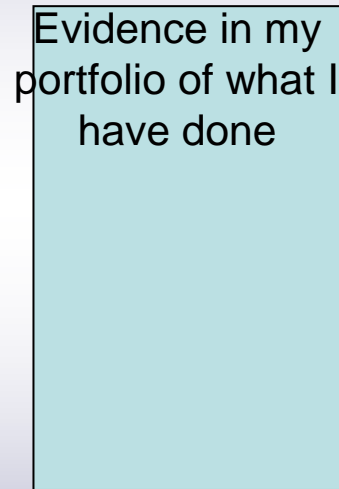
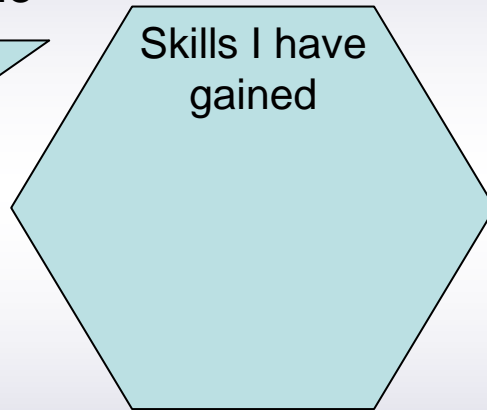

Challenge group comments
Award worker comment (by invitation)

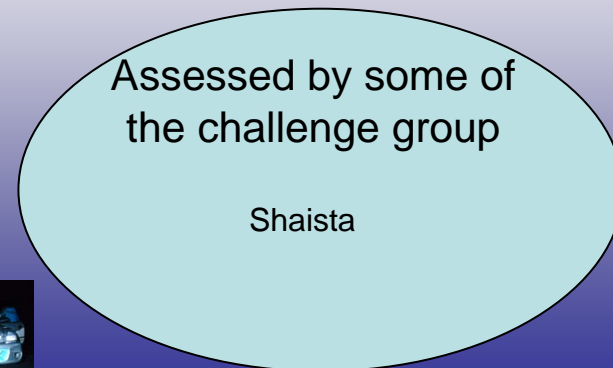

Time spent (hours)
Date Assessed



Celebration of Young People  
and their Achievements @ L-Shed  
(next door to the Industrial Museum),  
Bristol Docks

DAY	DATE	TIME
TUESDAY	NOV 1st 2005	15:30 - 20:30

# [BIG UP BRISTOL]

for more information see [www.youngbristol.com](http://www.youngbristol.com)

Award Presentations • BYCA • Young Bristol • Duke of Edinburgh's Award  
Personal Safety Training • Performances • Workshops  
Music • Cafe • Smoothie Bar

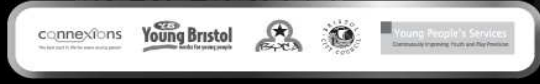

## Big Up Bristol 2005

'A celebration of young people and their achievements'  
Tuesday 1<sup>st</sup> November 2005 at L- Shed, Bristol Docks

### Programme Order

3.30-4.00pm	Registration and arrivals
4.00-4.30pm	Young Bristol Clubs Show – dance, football skills and Oliver Rush
4.30-5.00pm	Remix – music mentoring project
5.00-5.30pm	Break and Workshops Workshops include: Basement Studio, Head Massage, Breakdance, Climbing, Team Building, Self Defence, J'z Circus Daze, Juicy Blitz
<b>5.30-6.00pm</b>	Award presentations Young Bristol Awards and Vibe FM
6.00-6.30pm	Workshops and refreshments
<b>6.30-6.55pm</b>	Award presentations BYCA - Building a Better Bristol Awards presented by the High Sheriff of Bristol, Mr Roger Baird
6.55-7.00pm	MC Showdown – a young person's debut performance
7.00-7.30pm	Workshops and refreshments
<b>7.30-7.40pm</b>	Award presentations Duke of Edinburgh's Awards
7.40-8.00pm	Pete's Place – music and dance from the youth project at Lockleaze
8.00-8.15pm	Ten Sing
8.15pm onwards	Basement Studio

Big Up Bristol is compered by Logan (Freedom Youth) and Ricky (Young Bristol)





**YB**  
**Young Bristol**  
works for young people

activities   action   awards   news   have your say

**clubs**

[www.youngbristol.com](http://www.youngbristol.com)

The banner features a collage of images: a basketball player in a red jersey, silhouettes of people walking, and a close-up of a young person's face. The background is a mix of blue and red tones.

